

LLC Concern "Inmash"
Manufacturing of steering mechanisms (MRU)

**OUR GOAL IS TO IMPROVE THE REPUTATION AND WELFARE OF RUSSIA BY
DEVELOPING HIGH TECHNOLOGIES IN MECHANICAL ENGINEERING, TO MAKE A GREAT
CONTRIBUTION TO THE WORLD ECONOMY!!!**

Brief information about the company

LLC Concern "Inmash" is a dynamically developing enterprise of the Republic of Bashkortostan in the field of metalworking and mechanical engineering, revived at the production base of the former Plant of High-Precision Machine Tools (VTS) in Sterlitamak since 1983. LLC Concern "Inmash" has a certificate of production in the territory of the Russian Federation, localized Russian production, which supports the initiative of the government of the Russian Federation to improve import substitution.

The quality management system covers the development, production and repair of products in accordance with the EKPS classes 1680, 2520, 2410, 2510, 2530, 3460, 3710, 3720, 3825, 3830, 4320, 5420 and meets the requirements of GOST RV 0015-002-2012 and GOST R ISO 9001-2015.

Products:

- ball screw gears (SHVP);
- sliding screw nut (VGS);
- mobile drilling rig UBP - 30;
- knife planetary drive mechanism (MPPN);
- steering mechanism (MRU);
- steel tanks and reservoirs,
- horizontal and vertical
- equipment for oil companies (racks, work platforms, drilling bases, etc.)
- mast structure

Services:

- modernization, overhaul and current repair of machine tools (machine tool repair production);
- services for the production of metal structures of various
- difficulties (welding and assembly production);
- mechanical, heat treatment and gas-plasma cutting services;
- services for the automation and digitalization of production ("Inmash - Pro" suite).

Power steering mechanisms for UAZ vehicles

Since 1985, LLC Concern "Inmash" mastered and put into serial production steering mechanisms for trucks and cars of the UAZ brand. The mechanisms are designed to increase the moment created by the driver on the steering wheel in order to turn the steering wheels of the vehicle, both due to mechanical reduction and due to a hydraulic booster. The mechanism is used in hydraulic steering systems of cars.

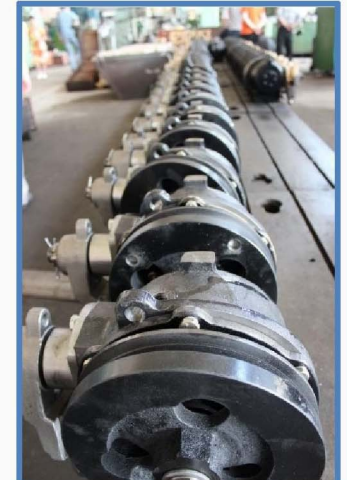
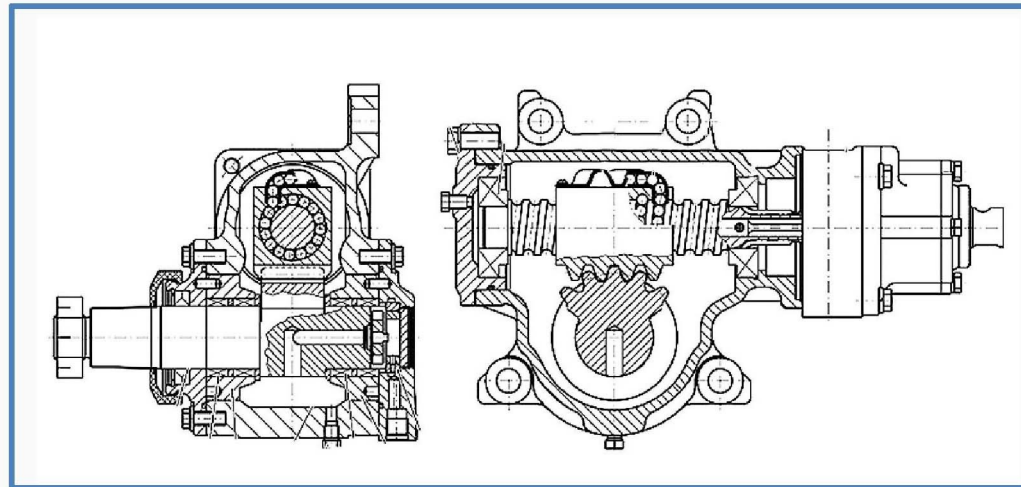

Application:

- ✓ UAZ 3160 Simbir -
- ✓ UAZ 31512 and modifications -
- ✓ UAZ 315195 Hunter with diesel engine 3M3514
- ✓ UAZ 452 and modifications



Our MRU:

- ✓ **Steering mechanism with built-in hydraulic booster 31601- 34.00.500**
- ✓ **Steering mechanism with built-in hydraulic booster 3303- 34.00.500**

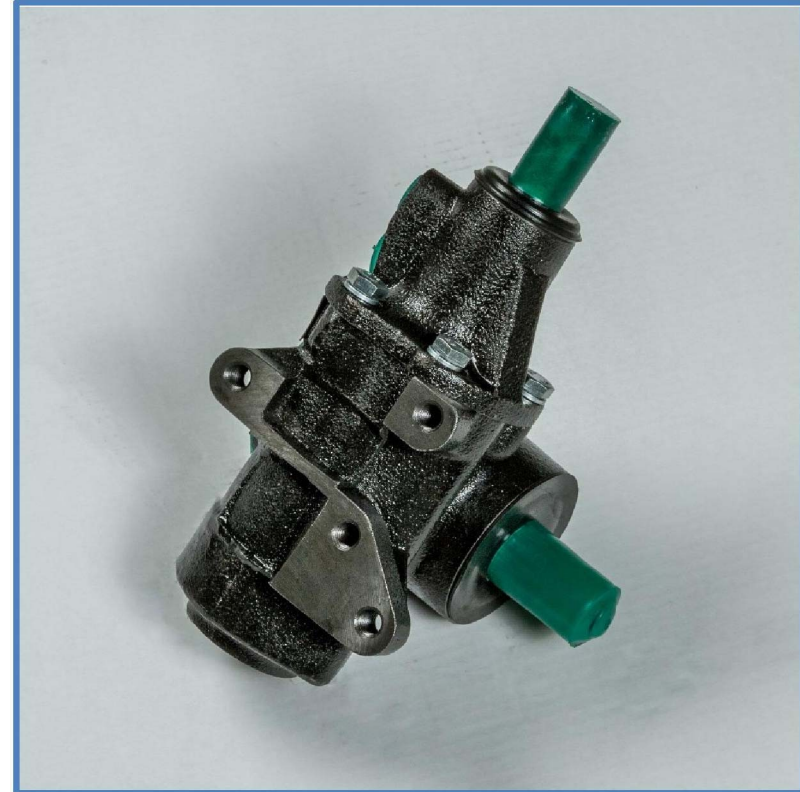

The accumulated experience and technological capabilities allow LLC Concern "Inmash" to master the production of similar products.

**Address: 453130, Republic of Bashkortostan,
Sterlitamak, Gogol St., 122**

E-mail: sale@inmash.info - sales department

Tel.: +7 (3473) 26-58-17, +7 (3473) 26-51-39

Website: <http://inmash.info>

Schedule: Mon-Fri 08: 00-17:00

